

5 Inch Dome



The Arecont Vision 5 inch dome is available for a wide variety of Arecont Vision mini cameras.

The combination of superior imaging and the 5 inch recessed dome provide a perfect solution to applications in which cameras need to be less noticeable.

- ❑ Indoor Applications
- ❑ Recessed Mounting
- ❑ Simple Installation
- ❑ Easy Access to Camera
- ❑ "Triple Gimbal" Mount for Precise Camera Adjustment
- ❑ Designed to House the Entire Line of 1, 2, 3, 5 and Day/Night Megapixel Cameras

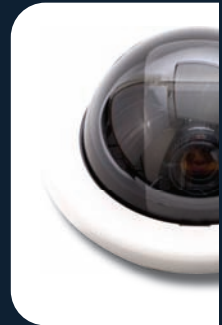
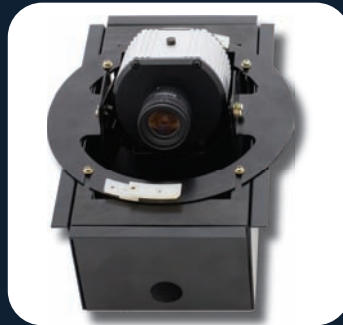
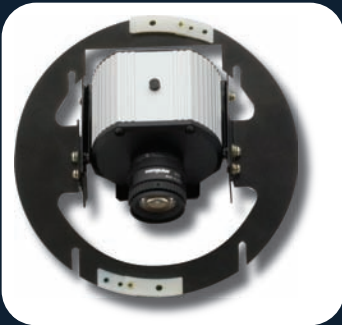

FULL VIEW IN ALL DIRECTIONS: Combining this dome with an Arecont Vision camera will ensure outstanding observation with excellent color sensitivity and high resolution.

EASY INSTALLATION: Easy installation, superior design for indoor usage.

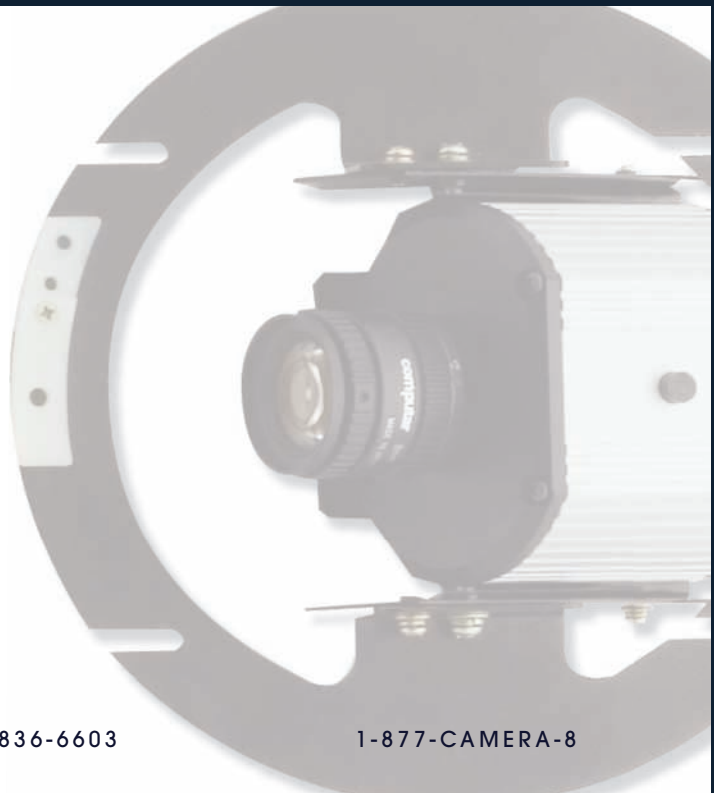

Specifications

CAMERAS

AV1300M, AV2100M, AV3100M, AV5100M:
Lenses: 4mm, 8mm, 12mm, 16mm

AV3130M :
Lenses: 8mm, 12mm, 16mm

MECHANICAL

Housing material: Aluminum

Dome Bubble: Vandal Resistant Polycarbonate

Bubble Diameter: 5 inch

Dust Protection cover box:
Length: 8.0 inch
Width: 4.5 inch
Height: 3.0 inch

Housing Height: 3 inch

Dome Height: 2.80 inch (70 mm)

Housing Diameter: 7 inch

Weight w/o camera: n/a

ENVIRONMENTAL

Operating Temperature:
0°C to 50°C

Humidity:
0 to 95 % relative, non-condensing

Enclosure Protection:
Indoor Only

